

MicroFogger 5 Pro Manual

Quick start guide

The following guide will show you how to setup your new MicroFogger 5 Pro for the first time. Follow each step carefully - failure to do so will cause frustration!

Read ALL parts of this manual to ensure you use this device safely, and correctly

1. Locate the MicroFogger and place it on charge using the included cable. The STATUS light will turn **orange** to indicate charging and will turn off once fully charged.
2. Locate the fluid tank and remove the rubber fill port cap. Fill it using the bottle of fog liquid, taking care not to over-fill. Replace the fill cap. Wait 15 minutes to allow the atomizer to saturate. This wait period is only required when using a brand new coil.

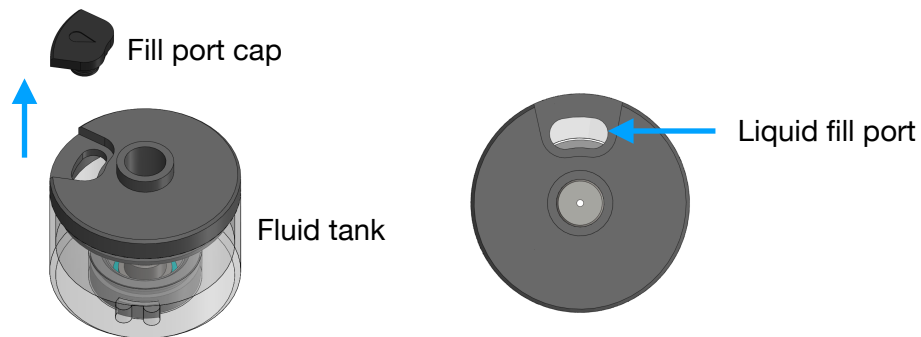

3. Once the MicroFogger is sufficiently charged, unplug it. Although we recommend fully charging, you may begin using it at any state of charge.
4. Remove the fluid tank caps (if installed) and screw the fluid tank onto the MicroFogger, ensuring it is not over-tightened. Place the safety cover over the tank.

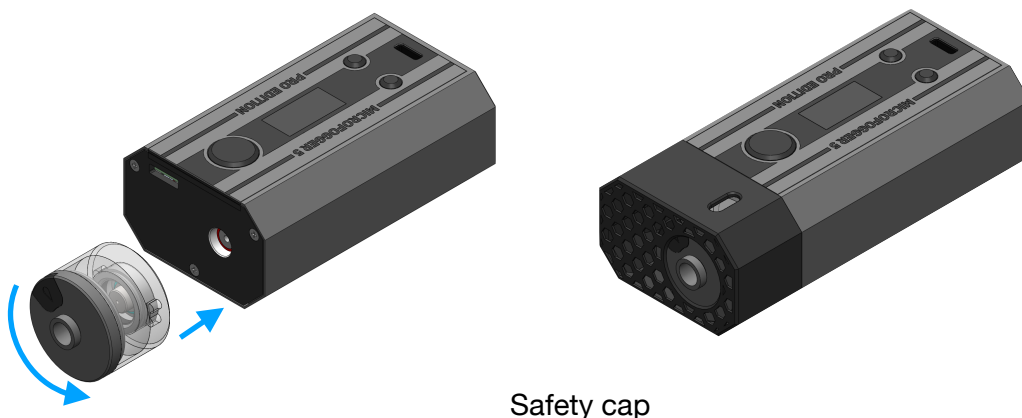

5. Turn the MicroFogger on using the small switch on the bottom. The screen will come on and the STATUS light will turn green.

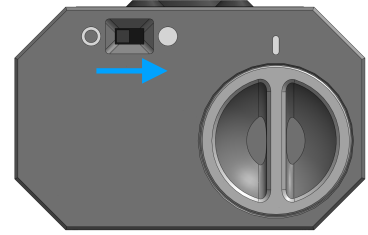

Before use, keep in mind a few important rules:

- Keep it mostly upright (vertical) during operation
- Closely monitor the fog liquid level and refill below 1/4 full
- Unscrew the fluid tank and turn the device off when not in use
- Unscrew the fluid tank for charging

After filling or storage, the MicroFogger may “spit” small droplets of fog liquid for the first few bursts. To avoid this, gently insert a Q-tip (provided) into the barrel of the device while twisting it clockwise until it bottoms out. This will absorb any excess liquid and prevent spitting. Remove Q-tip by twisting anti-clockwise. Never look into the barrel while device is operating!

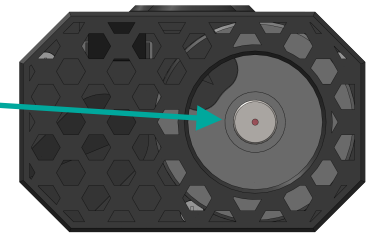

Operating the MicroFogger without fog liquid will burn out the replaceable heating coil. This would be indicated by the generated smoke smelling burnt.

Turn the MicroFogger off and unscrew the fluid tank before you store it. Unscrew the fluid tank when charging.

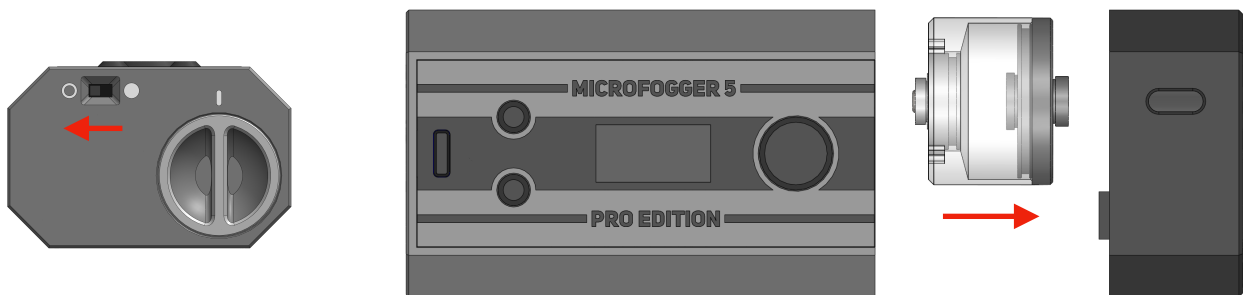

Full instructions continued on next page

On-board user interface

Switch

Slide to the right to turn device on, slide left to turn off

Smoke button

- Hold to begin smoke production, let go to stop
- Press once to return to previous screen in menu

Mode button

- Press to change between smoke density / speed adjustment
- Hold to enter the settings menu
- In settings menu, press to cycle through settings

Select button

- Press to cycle through smoke density/speeds on home screen
- Press to configure individual settings in menu
- Hold on some settings to quickly cycle through values

Screen user interface

The on-board screen allows you to change the MicroFogger's power levels and adjust various advanced settings. The overall structure of the menu is as shown:

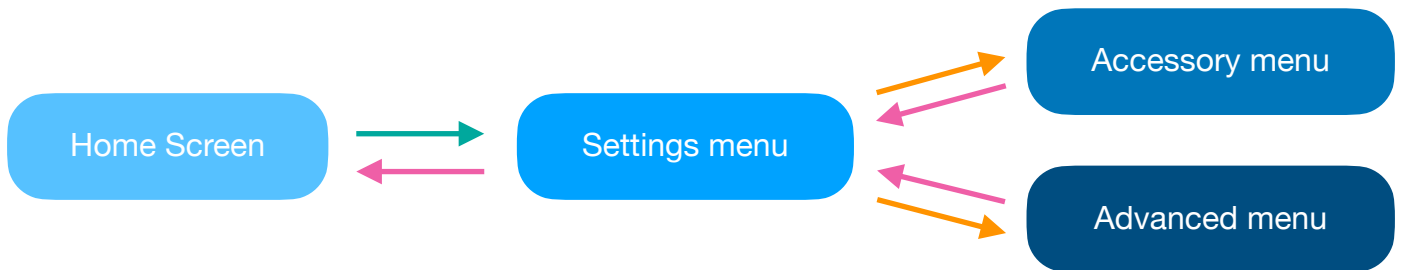
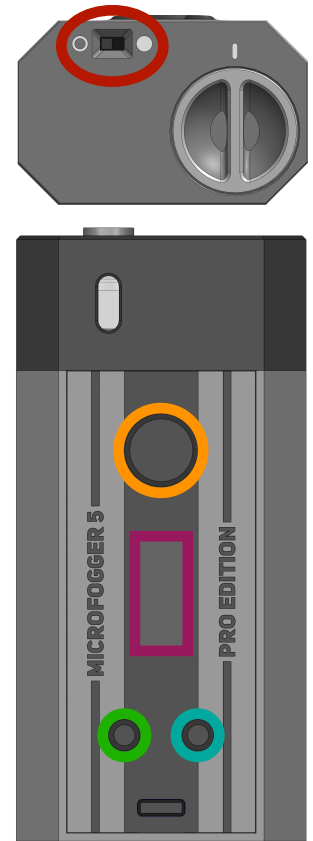

Hold MODE

Press SMOKE

SELECT (on respective menu item)

Home Screen

Here, you can cycle through smoke density levels by pressing the select button while the right bar is highlighted. To highlight and adjust the left airflow power bar, press the mode button. Hold the smoke button to see how changes affect smoke production in real-time.

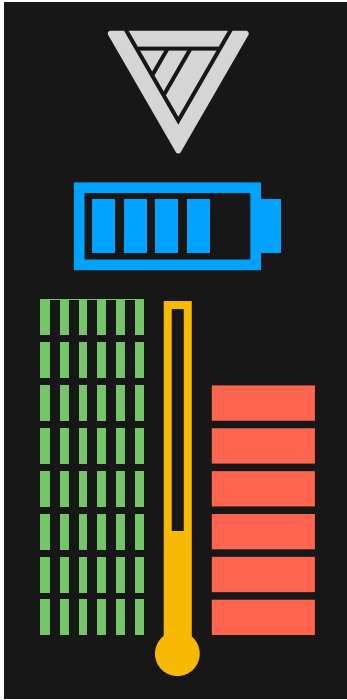

The top section where the logo is will indicate the status while operating.

The battery indicator shows the state of charge. The smoke created will become less dense as the level decreases

The left bar shows airflow power (smoke speed). We recommended to keep it full unless specifically needed.

The right bar shows heating coil power (smoke density). It is not shaded, so is selected for adjustment

The middle thermometer indicates fluid tank temperature. If the bar reaches the top, it will blink and lock the MicroFogger to allow it to cool down.

Settings menu

Enter this menu by holding the mode button for 4 seconds when on the home screen. Once entered, the mode button will cycle settings and select will adjust the selected setting.

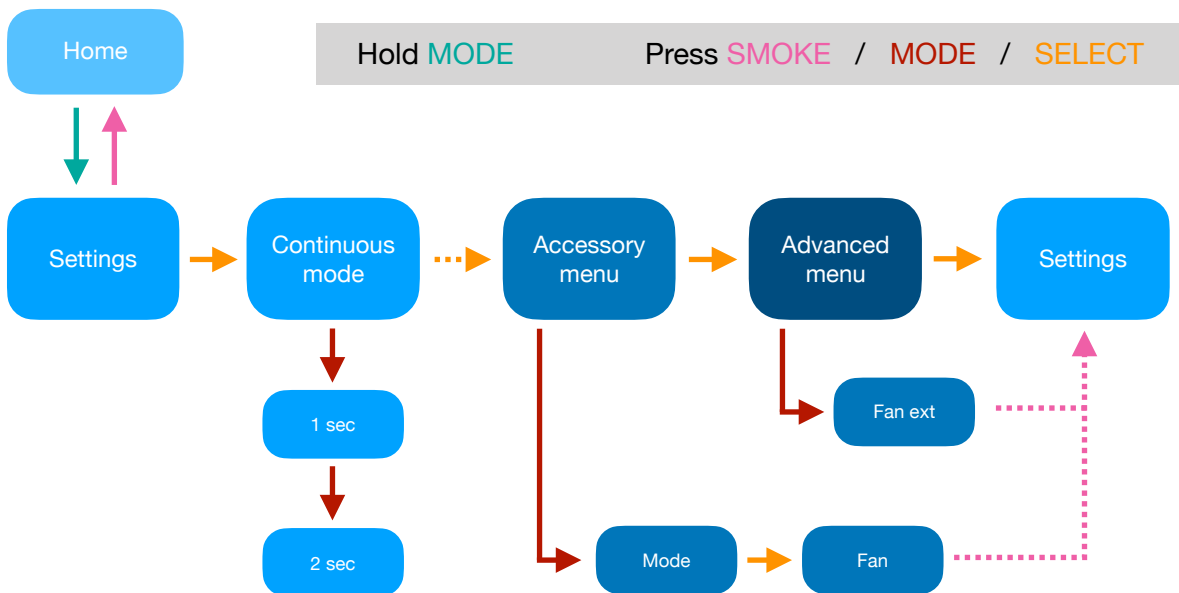

Note: Some settings have dependencies. For example to use loops, turn on continuous and delay

Tip: To quickly cycle through values on some settings, hold down SELECT

Ensure you have sufficient liquid when using auto-run modes!

Continuous mode - selects a duration for which the MicroFogger will stay activated after the trigger is pressed. While running, continuous operation can be cancelled by pressing SMOKE. Usually limited to 10s but with TIME LIMIT off, this is extended to 60s

Delay - Selects the duration for which the MicroFogger will wait until continuous mode is activated. Requires continuous mode to be on in order to work. Limited to 15 minutes

Loop - Selects the number of operational loops that the MicroFogger will perform. Requires continuous and delay mode to be turned on. Usually limited to 5 but with TIME LIMIT off, this is extended to infinite loops (- - -)

RC channel - Allows adjustment of remote control channel. By default, all 4 channels are in use for different power levels but once a specific letter is selected, the MicroFogger will only respond to that button on the remote.

Accessory Menu - Press SELECT to enter this sub-menu. Press SMOKE to exit

Mode - Selects whether an accessory is always on (CONT) or only when smoke is being generated (TRIG)

Diffuser power - Selects the power level for the diffuser accessory

Light mode - Selects the light accessory mode.

Color - Hold SELECT to cycle through 360 colors, white and RGB

Cycle speed - Selects how quickly a cycle of given light mode happens

RGB speed - How quickly the RGB spectrum cycles through colors

Advanced Menu - Press SELECT to enter this sub-menu. Press SMOKE to exit

These settings can be dangerous if adjusted improperly

RC program - Allows you to bind the MicroFogger to any 433MHz frequency remote control. Simply press select and follow the on-screen instructions.

Remote ON/OFF/TRG - Lets you turn off the MicroFogger's remote control functionality to avoid unintentional activation during important performances. When set to TRG, the RC will also activate auto-run modes

Time limit ON/OFF - Turns the time limit on or off. When off, the MicroFogger will not stop after 10 seconds of continuous operation. It will also unlock greater values in the continuous and loop mode menus. This is an advanced

feature and can be dangerous if used improperly. We recommend keeping it ON at all times.

Charge lock ON/OFF - Sets if the MicroFogger can be activated while charging. Keep this setting ON unless you are both charging and triggering simultaneously. Turning it OFF may result in unintentional activation while charging.

Control cable ON/OFF - Toggles the ability to use the USB port as a trigger. Keep this setting OFF unless using the control cable accessory

Info - This screen will display the software version number. Press select to see total runtime and battery voltage

Normal operation

Holding the SMOKE button when the MicroFogger is on will begin smoke production. To maximize heating coil lifespan, we recommend a 10 second limit on continuous use at high power settings, with a few seconds between each burst. Prolonged continuous use on a cold start can cause excessive heating coil wear.

Never run the MicroFogger without fog liquid in the fluid tank. This will instantly wear out the heating coil and make the smoke smell burnt. In extreme cases, if you keep running the MicroFogger after this indicator, small burning fragments of absorbent material may be ejected out of the nozzle, as the coil burns out. If the heating coil has worn out and the smoke smells burnt, immediately stop use and see the coil replacement instructions below.

We recommend keeping the MicroFogger mostly upright during use. This position allows the coil to optimally absorb the liquid, even if the tank is near-empty. If you require smoke output in a downward or sideways direction, we recommend using the hose adapter accessory to re-direct the smoke through a hose. If the fluid tank is >90% full, the MicroFogger can be used in any orientation,

Avoid prolonged use at low smoke speeds as this can cause the MicroFogger to “spit”. Always use the Q-tip method in the quick start guide to prevent “spitting” after storage or tank filling.

When finished, remember to turn the toggle switch OFF. Leaving the MicroFogger ON for extended periods of time may cause permanent battery damage and unpredictable behavior. Unscrew the fluid tank when you are done with using the device

To charge, unscrew the fluid tank and connect to power with a USB-C cable. The device can be charged either ON or OFF. Charging in the ON position will give a detailed battery level readout but will take marginally longer to charge.

Battery swaps

Li-ion batteries can be very dangerous when handled improperly. Only store batteries within MicroFogger or in safety cases, provided with spares.

To remove battery, turn device OFF and gently push in on the battery cap while rotating it anti-clockwise. Remove cap and hold MicroFogger vertical. Gently tap device on soft surface to eject battery. Pull battery out and immediately store in safety case

To re-install, gently push battery in, ensuring it is the correct way around as marked on casing. Re-install battery cap by pushing in and rotating 90° clockwise, while in correct cap orientation.

Tip: If you want to store the MicroFogger and prevent the switch from turning it on, install battery in reverse orientation, as it will be disconnected this way.

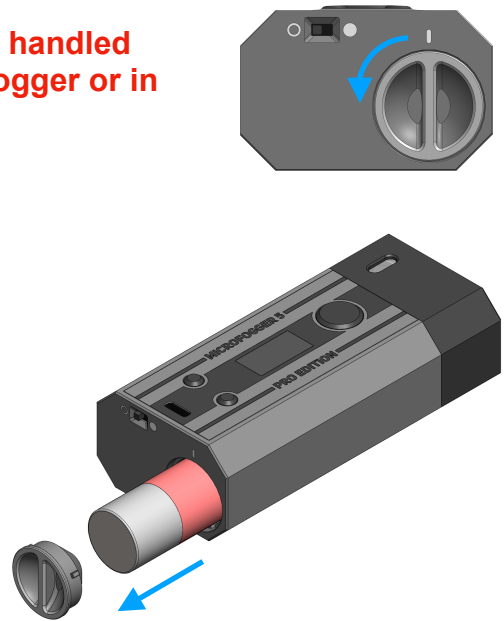

Heating coil replacement

If, during normal use, you notice that the smoke produced smells burnt, immediately stop and either swap fluid tank (if spare is available) or replace coil in existing tank:

1. Unscrew the fluid tank and remove fill port cap. Drain fluid by holding upside-down
2. Use the [tank tool](#) to unscrew the top cap, while holding the clear housing
3. Remove the tank base by pushing it out of the clear housing

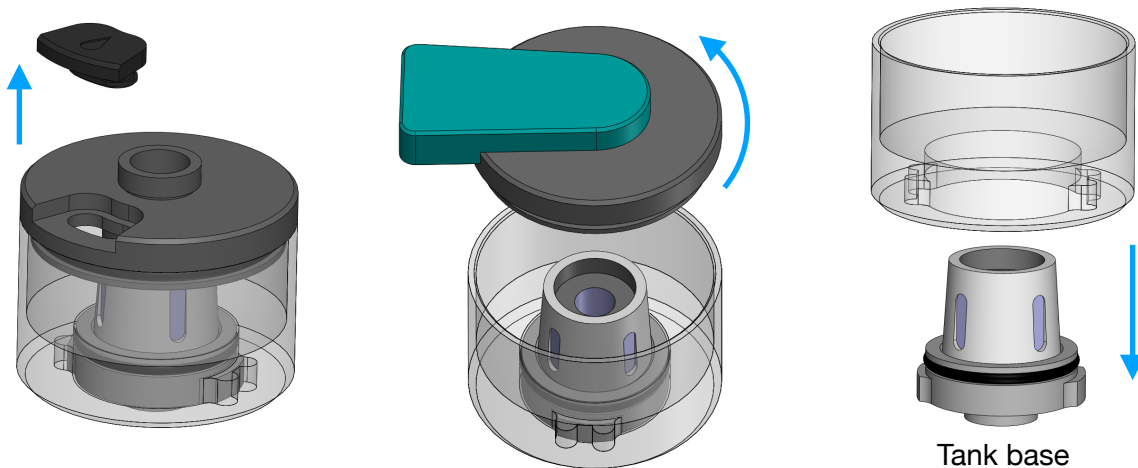

4. Use fingers or a gripping tool to unscrew the heating coil, while it is held in the clear housing as shown
5. Remove and save metal nozzle from bottom of worn coil. Discard worn coil
6. Install saved nozzle into new heating coil, ensuring the wire marked in yellow is wedged between the rubber gasket and nozzle.
7. Screw new coil back in, and re-assemble tank. Ensure O-rings are fitted properly

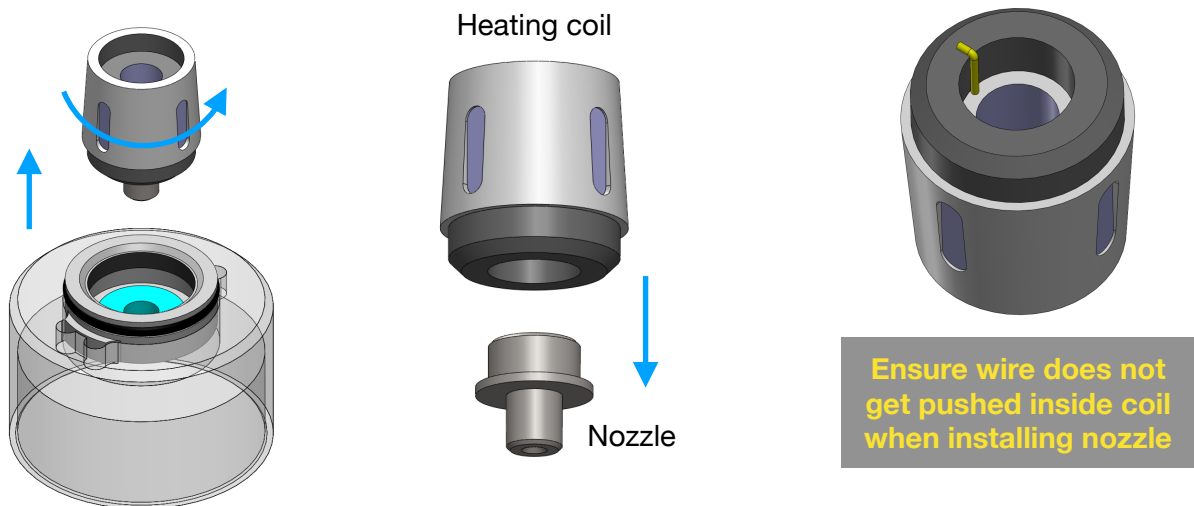

After installing a brand new coil, remember to let it soak in liquid for 15 minutes.

Tip: A worn out heating coil will have a black, charred interior while a new one is white

Storage and maintenance

To store the MicroFogger, fully charge it and turn it off using the switch. Ensure fluid tank is unscrewed and apply storage caps if available. Place it in a cool, dry place that is away from direct sunlight and any potentially flammable materials. The battery can be left inside the device.

If LEAK is displayed on the screen, you'll need to check the inside of the housing for leaks. You'll need a small Philips-head screwdriver to complete this maintenance.

1. Remove the safety cap and unscrew the fluid tank
2. Unscrew the 3 screws holding the front metal bulkhead
3. Slide top cover (with screen) forwards about 2 cm and then back in place
4. Remove the front bulkhead and observe inside of the housing
5. Use paper towel to wipe away any liquid if required
6. For more significant leaks, please consult disassembly manual

To reassemble:

1. Ensure top cover (with screen) is in normal position
2. Screw fluid tank onto front bullhead, ensuring center pin is in place
3. Ensuring good alignment, gently push bulkhead and tank assembly in place
4. Unscrew fluid tank, and screw the 3 screws back into place

If the MicroFogger gets oily from small droplets of fog liquid on the exterior, you can wipe it clean with a moist paper towel.

If the fluid tank gets oily or significantly wet with fog liquid, take it off of the device and wipe it clean. You can also wash it with clean water, but ensure you allow it to fully dry before re-installing, to prevent excess “spitting”

Troubleshooting

Before attempting any troubleshooting steps, please reset the MicroFogger first by holding the select and mode buttons at the same time for 10 seconds until “full reset” is displayed on the screen.

No smoke is emitted even though the device activates - First, check that the smoke density power isn't too low to notice. Next, ensure the fluid tank is screwed on sufficiently tight. If it is, attempt the following:

- Cut the cotton part off one end of a Q-tip, keeping the plastic handle
- Insert cut end of handle into the MicroFogger's barrel
- Apply some downwards pressure to re-seat any loose connections

Fluid tank leaking from ends - If you've over-filled the fluid tank, this may cause some leaks while the pressure equalizes. Wipe away any excess fog liquid and perform Q-tip cleaning method prior to installation on device. If leaking persists, you may have a worn heating coil, and needs to be replaced.

MicroFogger won't turn on - First, ensure that the battery is installed in the correct direction and the switch is ON. If the screen does not turn on, turn the switch OFF and plug the MicroFogger in to charge for several hours. If the device does still does not run on, the battery may have been over-discharged and needs to be swapped out.

MicroFogger won't charge - First, ensure that the battery is installed in the correct direction. If the orange charging light doesn't turn on, try using another charger and USB-C cable to diagnose whether it is an issue with the MicroFogger or not.

MicroFogger activates on when the placed on charge - This can occur when the charge lock setting is OFF and control cable setting is ON. Revert the settings to their default values.

MicroFogger produces a burning smell even with a new heating coil - There may be a very slight burning smell present in the first few second of operation with a new coil. If the smell does not disappear or gets more severe, stop using the MicroFogger and allow it to rest for at least another 15 minutes before continuing, ensuring that the fluid tank is full. If smell persists, replace heating coil

MicroFogger flickers ON/OFF when shaken - This indicates a loose battery spring that needs to be readjusted

MicroFogger spits out fog liquid when activated - After filling or storage, the MicroFogger may “spit” small droplets of fog liquid for the first few bursts. To avoid this, gently insert a Q-tip (provided) into the barrel of the device while twisting it clockwise until it bottoms out. This will absorb any excess liquid and prevent spitting. Remove Q-tip by twisting anti-clockwise. This can also happen at low smoke speed levels, increase speed level to avoid.

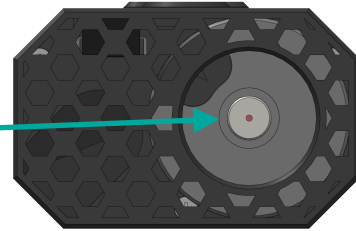

Safety

The MicroFogger 5 Pro is powered by a high-performance Lithium-ion battery. This type of battery presents a potential fire risk if handled improperly. The following safety guidelines aim to prevent any issues from arising:

- Never leave the MicroFogger charging while unattended
- Never run the MicroFogger in auto-run modes while unattended
- Always keep the MicroFogger away from any flammable materials
- Never expose the MicroFogger to temperatures over 60 degrees Celsius
- Avoid disassembling the MicroFogger unless instructed
- Always ensure the MicroFogger’s barrel is clear of debris
- If the MicroFogger sustains significant damage that punctures its battery, immediately cease operation and place it in a safe area outdoors to prevent any further damage to its surroundings or people should the battery sustain a thermal runaway.
- If the lower half of the MicroFogger heats up to uncomfortable temperatures of over 40 degrees Celsius, immediately cease operation (unplug it if it is charging) and place it in a safe area outdoors and wait for at least 10 minutes.
- Never attempt to power the MicroFogger using a home-made charging cable. If you do so, this will be at your own risk.
- Never attach, strap the MicroFogger to a person without a quick-release that can easily be operated by aforementioned person
- Always unscrew the fluid tank and turn the device off for storage
- Never store the battery “loose”, only store batteries in the device or in safety cases

To produce smoke, the MicroFogger evaporates a mix of Propylene Glycol and Vegetable Glycerin. Although these chemicals are both generally recognized as safe

and are commonly used in food additives and skin lotions, you must always follow the following safety points:

- Do not consume the fog liquid
 - Do not get any fog liquid into your eyes. Immediately flush affected eye with clean water for at least 15 minutes if this occurs.
 - Never use the MicroFogger near children under the age of 4 or pregnant women
 - Never use the MicroFogger near people with renal health issues
 - Never deliberately inhale the smoke produced
 - Never operate the MicroFogger if the liquid tank is empty
 - Never fog up a room to a visibility of less than 3m
 - Never use any fog liquid other than the liquid which provided by us. If you decide to do so, this would be at your own risk as we can only guarantee the safety and performance of our own liquid.
 - Immediately cease operation if the smoke begins smelling burnt
- If you feel nauseous, light-headed or exhibit any other adverse health-related side-effect, immediately cease operation and go to well-ventilated room with fresh air. Call a doctor if symptoms continue. Similarly, call a doctor if you are concerned about the impact of these chemicals on your health. Safety data sheets (MSDS) for the constituent chemicals can be found on [the fog liquid product page here](#).

During operation, the MicroFogger heats an internal metal coil in order to generate vapor. To prevent any heat-related issues please follow these guidelines:

- Never touch the fluid tank during operation as it can burn you
- Use the on-screen temperature indicator to tell advise when tank is hot
- Always allow fluid tank to cool down prior to handling
- Never aim the MicroFogger at people or animals that are within 1m of range as sometimes, small droplets of hot fog fluid can exit the nozzle
- Never look directly into the MicroFogger's nozzle while it is running
- If the MicroFogger is used without liquid, the heated metal coil will start burning the absorbent material surrounding it. This may cause a small flame to appear from the tip of the MicroFogger. Ensure that you never run the MicroFogger without liquid as this sort of incorrect operation can cause injury and damage.

Finally, there are a few more miscellaneous guidelines that must be respected:

- Never allow anyone under the age of 18 to use the MicroFogger
- If the smoke starts smelling burnt, immediately cease operation and replace the heating coil with a new one.

Vosentech LLC will not accept any responsibility for property damage or bodily harm caused by the improper use of the MicroFogger or any other of its products. It is the user's responsibility to use good judgement and knowledge of the risks detailed above to correctly and safely operate the device. If you are unwilling to accept the risks associated with the use of this device, immediately return it back to us for a refund.

Package contents

The following items should be included in your order of the MicroFogger 5 starter kit:

- MicroFogger 5 Pro
- Fog liquid bottle
- Remote control
- USB charging cable

If you've purchased the Ultimate kit, the following additional items are included:

- Additional bottle of fog liquid
- Hose adapter
- LocLine adapter
- LocLine tubing
- Rake attachment
- Circular diffuser
- Liquid fog attachment
- 2 spare V5 coils
- Tank disassembly tool
- Spare battery in safety case
- Carry case with foam insert

Additional features

The MicroFogger 5 Pro supports several additional features that'll make it easier for you to incorporate it into your own custom projects should you decide to do so. Please note that although these modifications are officially supported, you will void your MicroFogger's warranty should you decide to proceed since there is a potential to damage the internal electronics if you are not careful. While the following guide will detail each step to make the process as easy as possible, we still advise that you only attempt these modifications if you believe you have sufficient technical knowledge.

Proceed at your own risk

Wired manual control

The MicroFogger can be triggered via its USB port to allow for automated control or to let you reliably activate it over long distances where the remote control may be unsuitable. This can be done by simply connecting the two data pins (pins 3 and 4) of the USB-C port together. To access these pins, you'll need to get one of our control cable break boards. Using the diagram on the back of the breakout board, connect your switch or relay to the two pins on either side of the button symbol. You will need to turn the control cable setting ON in order to allow the cable to work.

V1.1

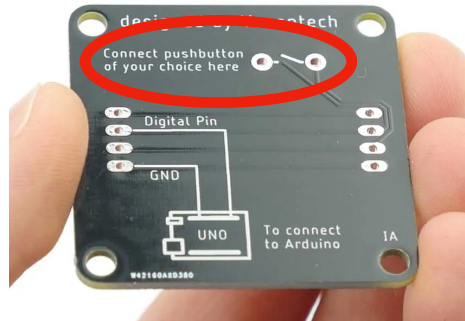

Incorrectly wiring or accidental contact between any wires other than the data ones can lead to irreversible damage that is not covered by the warranty.

Wired digital control

Similarly, the MicroFogger can also be controlled using a common microcontroller such as an Arduino. In order to do so, you'll need to connect the black GND pin of the breakout board to the ground pin of the microcontroller. You'll then be able to send a HIGH or LOW signal to the input pin in order to turn the MicroFogger on or off. The signal voltage can range from 3V to 5V. You will need to turn the control cable setting ON in order to allow the cable to work.

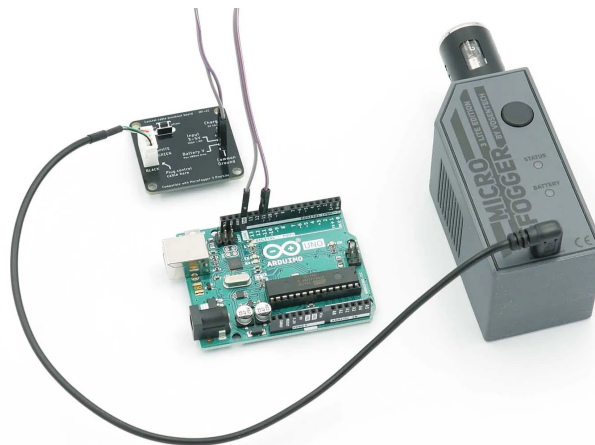

External Power

The MicroFogger 5 Pro can be configured to operate while charging so it is possible to power it off of a USB battery bank or any other other 5V power supply. If using a battery bank, you can connect it using the included micro USB cable. If a USB port is inaccessible, our control cable breakout board can be used. Simply connect the positive terminal of a 5V power supply to the charging pin on the breakout board and the black wire to the ground pin. This will also allow you to use wired control while keeping the MicroFogger on charge as long as you have turned off the charge lock setting in the advanced menu.

Support and FAQs

Can the MicroFogger trigger smoke alarms?

Yes, if enough smoke is produced then ionization and photoelectric smoke alarms will be activated. Traditional heat-activated smoke alarms and sprinklers won't be affected

Is it possible to change the smoke color?

Sort of! With the MicroFogger 5, we have the ColorSmoke attachment available, that will light up the generated smoke in various colors. Unfortunately, it is not possible to actually change the smoke color itself.

Can I breathe in the smoke?

During proper operation, the fog produced is considered to be non-toxic but we do not recommend breathing it in anyway. The smoke can only become toxic if the safety precautions regarding the replacement of worn-out heating coils are not followed, and you breathe in smoke that strongly smells burnt.

What is the fog liquid made out of?

Our fog liquid consists of a high purity vegetable glycerin and propylene glycol mixture. These chemicals are commonly-available and may be found in local shops as base liquids for electronic cigarettes. The MSDS documents for these chemicals can be found on the fog liquid product page on our website, [linked here](#).

Can I use liquids from other smoke machines?

Liquids from other fog machines are usually far less viscous than our composition so if used in the MicroFogger, they are unlikely to produce any smoke. We can only guarantee the safety and performance of the fog liquid that we sell so if you decide to experiment with other compositions, this would be at your own risk.

How long does the smoke linger in the air?

Depending on the atmospheric conditions, the smoke can remain in the air for up to an hour after being released. The main factor affecting this is whether or not there is any air movement, drafts or wind will greatly accelerate the smoke dispersion.

Do MicroFogger 4 heating coils work with the 5?

Sort of! The MicroFogger 4 coils have an additional metal piece on the bottom that needs to be removed to make way for the MicroFogger 5's nozzle. Once removed, they are compatible.

What obstacles can the remote control signal go through?

It depends on the exact situation but in general, you will be able to control the MicroFogger through several thin plaster walls. Similarly, if you decide to put it into cardboard or fabric enclosure, you shouldn't encounter any issues. On the other hand, metal barrier such as car doors will usually block the signal although we have had luck with activating the MicroFogger inside a car hood, with relative ease.

Can I control the MicroFogger 5 Pro via a wired remote?

Yes, the USB charging port also doubles as a signal input which allows you to trigger the MicroFogger using a switch, relay or microcontroller of your choice. You'll need our control cable accessory to access this functionality.

If you believe that your Microfogger is faulty, please check the troubleshooting section of this manual. If your problem still persists, please consult the following page:

<https://vosentech.com/index.php/repairs-and-replacements/>

If, after reading the above page, you'd like to return the item, please see the instructions below:

<https://vosentech.com/index.php/returns-refunds/>

If you'd like to contact us, feel free to use the email address or phone numbers below. If it is a specific question about your order, please include your order number that starts with VT which can be found on your printed invoice.

support@vosentech.com

+1 (215) 649 7702